



***Wireless
Boatlift
Controls***

Installation and User Guide

1 MOTOR SYSTEMS

The base 1 motor boatlift control system is suitable for most boatlift applications that have one drive motor for the lift. The compact unit gives the user complete control of your boat or PWC lift while approaching from the water or simply standing on the dock. This guide is intended to specifically aide in the installation and use of this model.

2 MOTOR SYSTEMS: TILT

Tilt systems are for large boat lifts that have two motors. These systems have the option to manually shut one motor off in order to “tilt” or level your boat. This is usually needed on this type of lift to ensure that both motors stay in sync. The toggle switch located on the gel pad is used to shut off one motor. Under normal operation the toggle should be flipped to the up position to allow for both motors to run. When leveling is necessary flip the switch to the down position to disable one motor. Specific diagrams for this system come as supplemental page on equipped units. These diagrams can be replaced by submitting a request to support@boatliftcontrols.com. Your serial number will be required to verify the version purchased.

2 MOTOR SYSTEMS: INDEPENDENT

This system is designed to switch the remote control between two “independent” single motor lifts instead of purchasing separate controls for each lift. There is a toggle switch located on the gel pad that is used to swap between lifts. Wire sizing for this unit should be based on the largest horsepower rating of the two motors and the furthest overall distance to a motor. These diagrams can be replaced by submitting a request to support@boatliftcontrols.com. Your serial number will be required to verify the version purchased.

BREAKER AND WIRE SIZE RECOMMENDATIONS

120 VAC Line Voltage

Number of Motors	Motor HP	Amps to run	Breaker Amp Rating	Distance from Main Breaker to Motor				
				50 ft	100 ft	200 ft	300 ft	400 ft
1	1/2	8.8	10	12	10	6	4	4
1	3/4	10.8	15	12	8	6	4	3
1	1	12.8	15	10	8	6	4	3
1	1 1/2	17.0	20	10	6	4	2	1
2	1/2	17.6	20	10	6	4	2	1
2	3/4	21.6	25	8	6	3	1	-
2	1	25.6	30	8	4	2	1	-
2	1 1/2	34.0	35	6	4	1	2/0	-

240 VAC Line Voltage

Number of Motors	Motor HP	Amps to run	Breaker Amp Rating	Distance from Main Breaker to Motor				
				50 ft	100 ft	200 ft	300 ft	400 ft
1	1/2	4.4	5	14	14	12	10	10
1	3/4	5.4	10	14	14	12	12	10
1	1	6.4	10	14	14	12	12	10
1	1 1/2	8.5	10	14	14	10	10	8
2	1/2	8.8	10	12	12	10	8	6
2	3/4	10.8	15	12	12	10	8	6
2	1	12.8	15	12	10	8	6	4
2	1 1/2	17.0	20	12	10	8	4	2

INSTALLATION

Tool Necessities: Volt Meter, No. 2 Philips Screw Driver, Flat Head Screwdriver, Wire Strippers/Cutters.

1. Make a plan before getting started!
 - a. You will need to have at least 1ft of slack in each cord (1 from each motor and 1 from the power feed), you will also need to assess how the box will be mounted.
 - b. Many pole mount applications require a baseplate; a length of 2x6 treated wood is acceptable. If you are replacing an existing manual switch, verify that the lift is working properly.
 - c. It is best to hang the control box high enough to be out of the reach of children.
 - d. Identify the voltage that your system is setup for then verify that the control box voltage is setup to match.
 - e. Ensure that the that the circuit breaker and wire size is correct for your system, see the chart for a general recommendation. Overload protection is not provided within the control box.
2. If possible, make sure the lift is in a neutral position so that it can go up or down several feet without obstruction.
3. Shut off power to the circuit breaker, then verify with a volt meter that the line voltage reads 0 Volts AC.
4. Remove the remote(s), paperwork, and hardware from inside the control box and set it aside.
5. Install the control box mounting hardware. The tabs may be oriented in several ways based on preference.

6. Hang the control box using the supplied stainless deck screws.
7. Open the control box and remove the 4 screws holding the gel pad in. Then gently take the gel pad out taking note of the attached ribbon cable. The ribbon cable may be unplugged from the circuit board by gently pulling on the black connector. Set the gel pad aside.
8. Remove the circuit board by unplugging the 9-pin Molex connector and set it aside.
9. Establish which wiring diagram goes with your application based on your input voltage.
10. Verify that the transformer is configured correctly for your application. Refer to the wiring diagram.
11. Untuck the green wire with yellow wire nut, and if using a 120VAC power supply untuck the white wire with yellow wire nut as well.
12. Connect the two incoming power wires at L1 and L2 according to the diagram making sure to route the wires so that they tuck cleanly toward the back of the box. Then connect the motor wires. Connect the ground wires last.
13. At this step it is best practice to reconfigure your motor according to the appropriate attached diagram. Failure to do so could result in motor damage. However, many times this step is unnecessary. Galaxy is not responsible for motor damage, use discretion!
14. Verify that all connections are good and according to the diagram, then identify the bypass button located in the center of each contactor turn the power on to the unit.
15. Using an insulated rod or screwdriver depress the down contactor (green arrow). Verify the lift goes down. Next depress the up contactor (red arrow). Verify the lift goes up. If the lift moves correctly

proceed to the next step. If the direction is backwards shut off the power and swap the orange and black motor wires at the control box. For any other issues contact technical support at 888-317-7203 or support@boatliftcontrols.com.

16. Shut off power to the unit and verify with a volt meter. Then reconnect the circuit board and reinstall the gel pad. Make sure to route the gel pad ribbon so that there are no sharp bends or folds and verify that the spring antenna is not touching any metal.
17. Turn power on to the unit and make sure that the power LED on the gel pad is illuminated. Test remote transmitter functionality. If necessary, see remote programming.

GEL PAD BUTTONS AND FUNCTIONS

The Gel Pad is the Primary control center for your boatlift. Here you can turn your unit off and on or send the lift upward or downward. The remotes are also programmed from the Gel Pad.

For marine applications the “2” button is not used; simply use the arrows to control your direction.

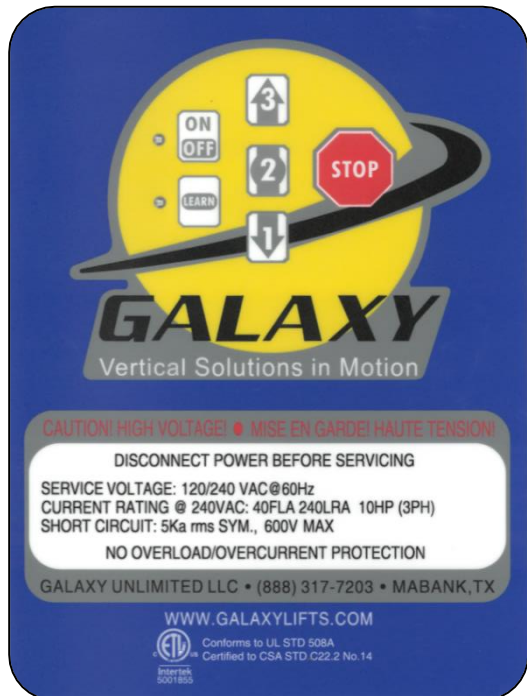

TRANSMITTER PROGRAMMING AND INFO

The remote transmitters are designed to be water resistant for most accidental submersions, and they do float just in case!

Transmitter Replacement Battery Size: A23

Read through instructions thoroughly before starting. You must move quickly during this process! The control board will exit the programming mode after 7 seconds of inactivity

1. Unplug or shut off main breaker to unit for 10 seconds then turn it back on.
2. Press and hold the learn button on the gel pad until the green LED beside the button lights up (approximately 3 seconds)
3. Press either the up or down button on your remote, you will see a corresponding flash from the learn LED.
4. Give the learn mode about 10 seconds to expire, you will see a rapid flash from the Learn LED
5. Now test the remote(s) to see if the programming was successful!



120 VAC WIRING LAYOUT

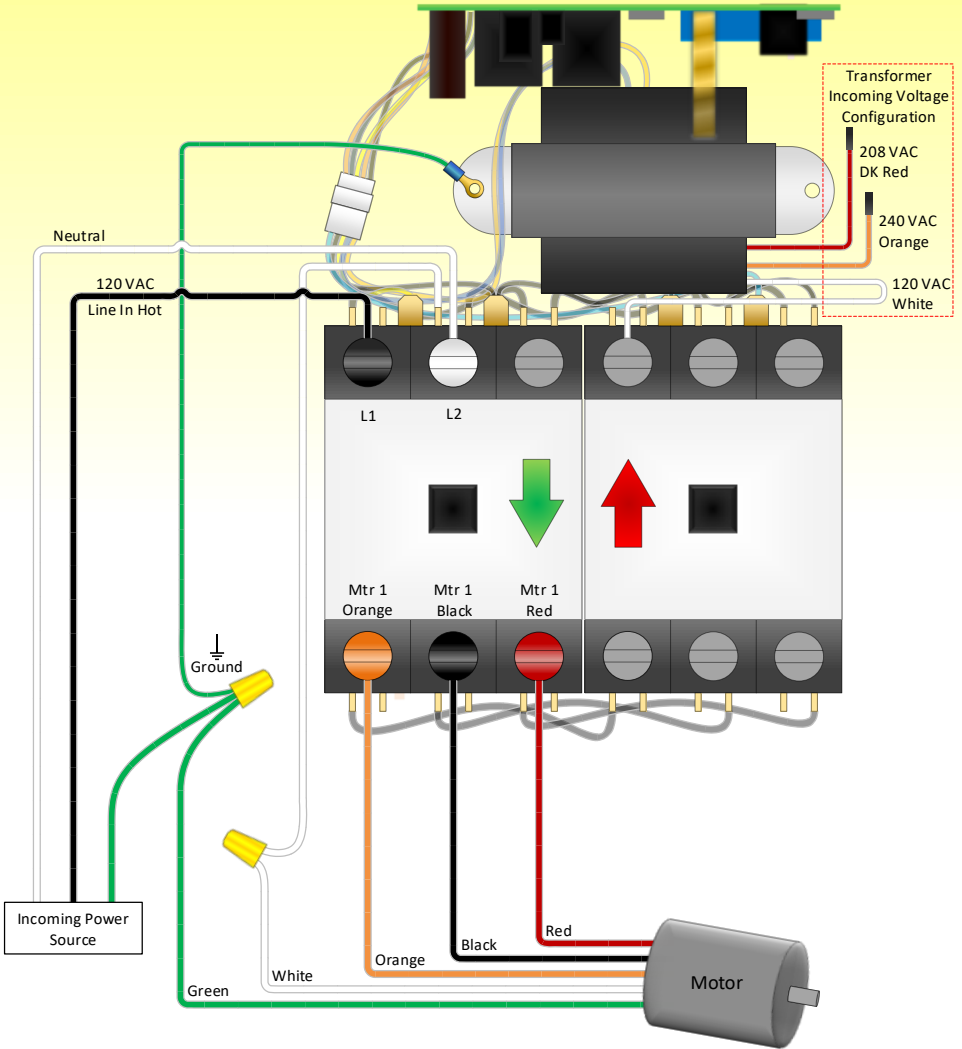

240 VAC WIRING LAYOUT

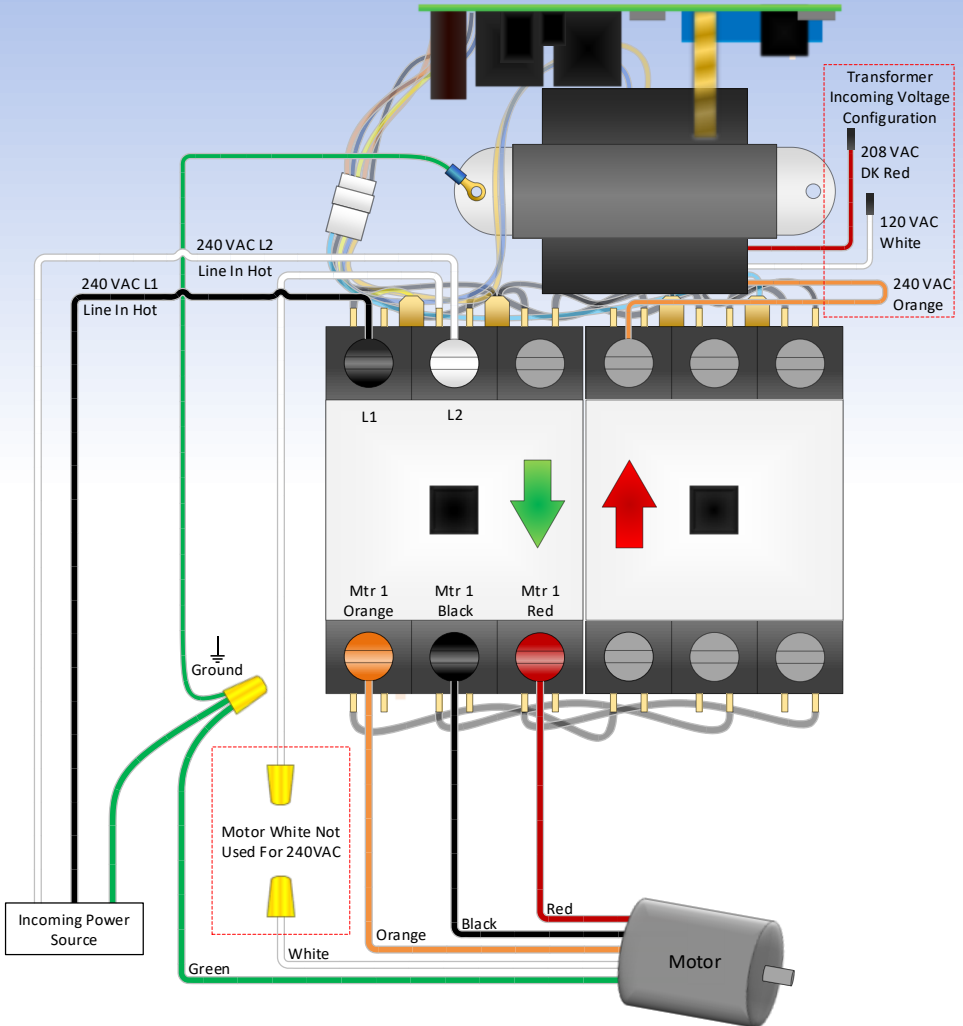

CONFIGURE YOUR MOTOR



120VAC Standard "T" and "Colored" Wiring

Leeson, Marathon, AO Smith, Electrogear, Baldor, Dayton and others that follow a Standard "T#" or Standard "Colored" Wiring Scheme.

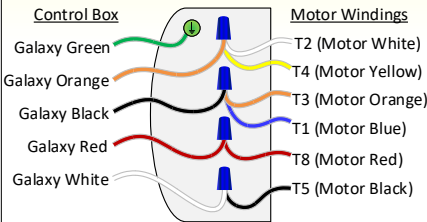

240VAC Standard "T" and "Colored" Wiring

Leeson, Marathon, AO Smith, Electrogear, Baldor, Dayton and others that follow a Standard "T#" or Standard "Colored" Wiring Scheme.

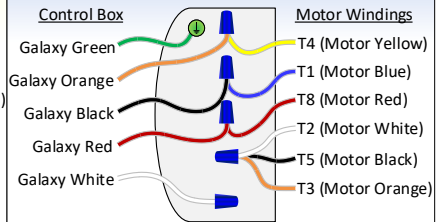

120VAC Marathon and GE Wiring

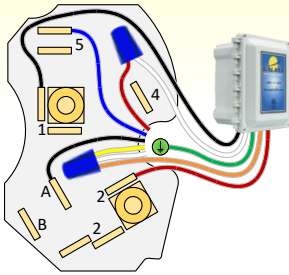

240VAC Marathon and GE Wiring

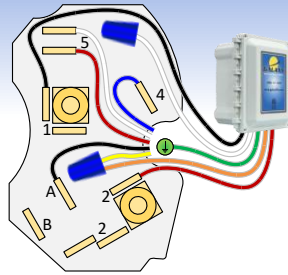

120VAC Regal Beloit's A.O. Smith and Aqua Marine Supply (AMS)

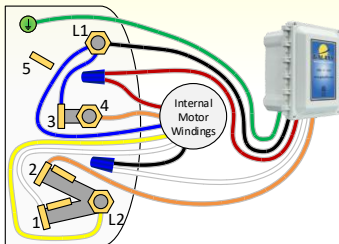

240VAC Regal Beloit's A.O. Smith and Aqua Marine Supply (AMS)

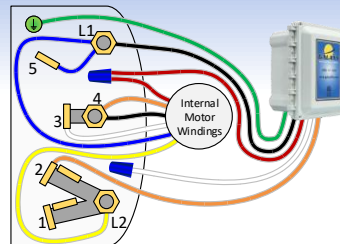

Installer Notes

Galaxy Unlimited, LLC Boatlift Control Box Warranty

This warranty is for the electrical components of the Remote-Control Box which begins on the date of delivery from Galaxy Unlimited, LLC for a period of 1 year thereafter. During this period, Galaxy Unlimited, LLC will replace electrical components, without charge, for the components of the Remote-Control Box, or any part or piece thereof, which exhibits a manufacturing defect or defect in craftsmanship. Defect is determined at the absolute and sole discretion of Galaxy Unlimited, LLC.

To submit an acceptable claim under this limited warranty, the Original Purchaser must provide the following information in writing to:

Galaxy Unlimited, LLC
6470 State Highway 198
Mabank TX 75156

- Full name and Address
- Serial Number of Unit
- Clear and specific description of the defect
- Ship malfunctioning Remote Control Box to above address for confirmation/evaluation at the expense of the customer.

This limited warranty is valid only when such products are used under normal conditions of recommended use. This limited warranty does no cover replacement or repair of any part there of damaged by acts of God, abuse, accident, misuse, neglect, alteration, repair, disaster, overloading, negligence, unauthorized use, improper installation, improper testing, improper product selection, failure to follow maintenance recommendations, failure to follow instructions or warnings, or any other case beyond the control of Galaxy Unlimited, LLC.

All warranties implied by law, including implied warranties of merchantability and fitness for a purpose, are disclaimed or, if a disclaimer is not permitted by applicable state law, are expressly limited to the durations of the coverage period set forth above